

# CCD Color Camera

## KP-D531U

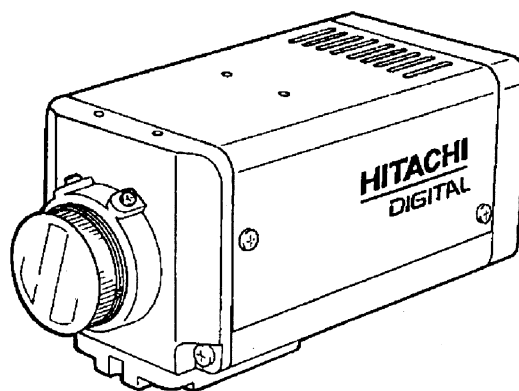

### Operation manual

Before using the camera, please read this operation manual carefully and keep this manual on file for ready reference in the future.

Hitachi Kokusai Electric Inc.

### Table of contents

CAUTION FOR SAFE OPERATION .....	A	<b>Setting menu description</b> .....	12
IMPORTANT NOTICE .....	K	Setting menu composition .....	12
<b>General</b> .....	1	Menu operations .....	13
<b>Features</b> .....	1	Main menu .....	14
<b>Operating considerations</b> .....	2	Title menu .....	15
<b>Phenomena inherent to CCD image device</b> .....	3	Light control menu .....	17
<b>Section names and functions</b> .....	4	AGC setting .....	20
<b>Connections</b> .....	6	Shutter speed setting .....	21
<b>Lens</b> .....	7	Sensitivity enhance setting.....	22
Recommended lenses .....	7	Raising sensitivity by color-B/W selection.....	22
Note on lens selection .....	8	White balance menu .....	26
Installation of CS-mount lens .....	8	Digital zoom menu .....	28
Lens selector switch .....	9	Sub menu .....	29
Flange back adjustment .....	10	<b>Color temperature and</b>	
<b>Camera mounting</b> .....	11	<b>White balance adjustment</b> .....	31
		<b>Remote menu operation</b> .....	32
		<b>Remote sensitivity operation</b> .....	33
		<b>Specifications</b> .....	35
		<b>Accessories</b> .....	36
		Supplied accessories .....	36
		Optional accessories .....	36

## General

Hitachi's KP-D531U is a CCD color camera utilizing a newly developed digital signal processor (DSP) processing a wide dynamic range. Clear pickup is enabled in ordinarily difficult situations, such as scenes with strong differences in lighting among components of the same

## Features

### High sensitivity, high resolution

- The high density interline type CCD sensor with on-chip micro-lenses enables low-light pickup down to 0.2 lx (with F1.4 lens, AGC maximum) and Horizontal resolution of 480 TV lines.

### High picture quality

- Digital signal processing LSI.
- Contour compensation by digital technology and 2H vertical enhancer.

### Various functions

- Day / night continuous surveillance
- Auto tracking white balance (ATW)
- Electric shutter speed
- Electric sensitivity enhance
- Backlight compensation (BLC)
- Text display (character generator)
- Digital zoom
- Digital noise reduction (DNR)

1

## Section names and functions

### Tripod adaptor holes

See camera mounting on page 11.

### Lens connector [LENS]

Connect lens cable when using an auto iris lens. See page 9.

### Camera mounting hole

See page 11.

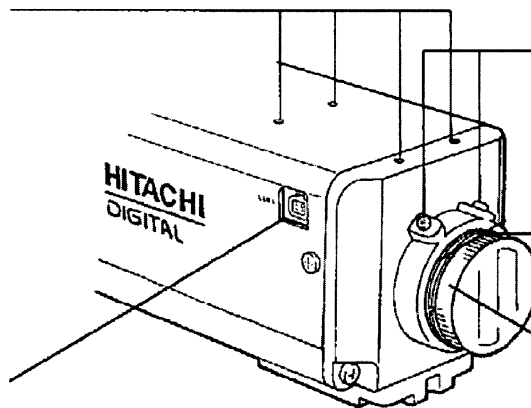

### Lens mount screws

See page 10.

### Lens mount ring

See flange back adjustment on page 8.

### C-mount adaptor

See installation of CS-mount lens on page 8.

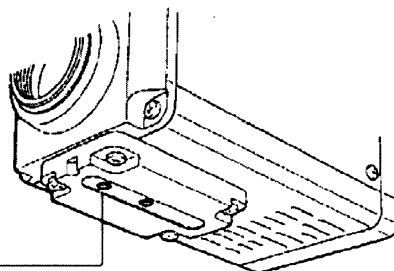

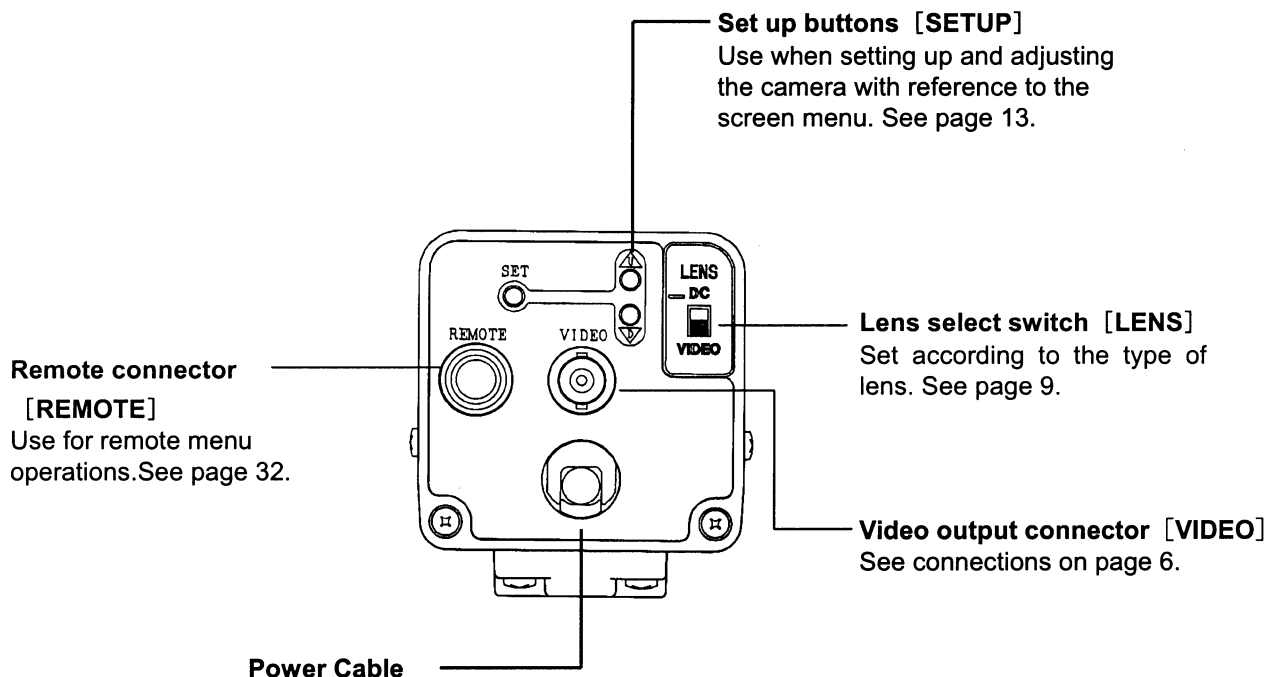

## Connections

### Video output connection

Connect the video output of the camera to the video input of a monitor or other equipment. When using a "loop through" connection of two or the more monitors, set the 75Ω switch of only the final monitor to ON. Determine the type of cable according to the distance of the connected equipment. The maximum cable lengths indicated below are recommended for avoiding appreciable picture degradation.

3C-2V	· · · ·	150m
5C-2V	· · · ·	200m
7C-2V	· · · ·	300m
10C-2V	· · · ·	400m

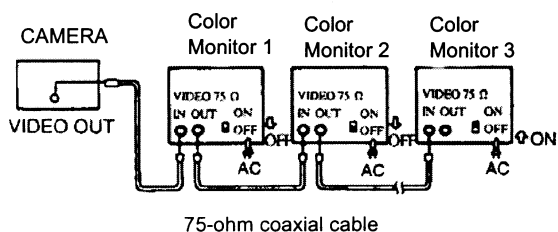

Set the 75Ω switch of only the final monitor to on.  
Set the 75Ω switch of other monitors to off.

# Lens

## Recommended lenses

Use an auto iris lens having a plug pin arrangement conforming to EIAJ (Electronic Industries Association of Japan) specifications. Following is a list of recommended lenses (all are CS mount).

Type		Lens model	Specification			DC/VIDEO switch
Manual iris	1/2	HS316	3.7	mm	F1.6	DC
		HS614B	6	mm	F1.4	
		HS1214D	12	mm	F1.4	
Auto iris ( with iris amp )	1/2	HS316TE	3.7	mm	F1.6~90	VIDEO
		HS614TE	6	mm	F1.4~90	
		HS1214TE	12	mm	F1.4~90	
		HS316E	3.7	mm	F1.6~300	
		HS614E	6	mm	F1.4~300	
		HS1214E	12	mm	F1.4~300	

### Note:

If another type of lens is used, it may detract from camera performance or there may be difficulty in attaching the lens. When procuring, be sure to specify the EIAJ compatible plug.

7

### Note on lens selection

- 1) Observe the maximum size limit (A in the figure) When installing the lens. Internal damage can occur if a larger lens is used.
- 2) Avoid using a lens that is heavier than the camera. If unavoidable, be sure to fix the lens itself on a support.

### Installation of CS-mount lens

C-mount adaptor is provided for the camera in the factory. When using a CS-mount lens, unscrew and remove the C-mount adaptor. Save the C-mount adaptor for possible future.

### Caution:

A heavy lens can disturb the balance with respect to the camera and possibly result in damage.

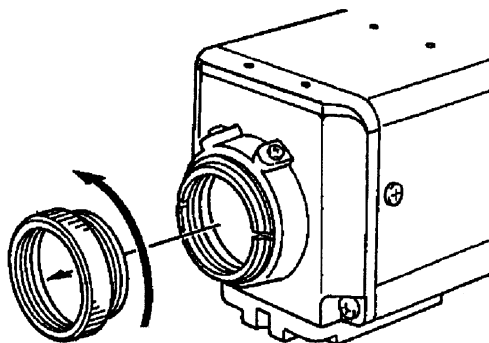
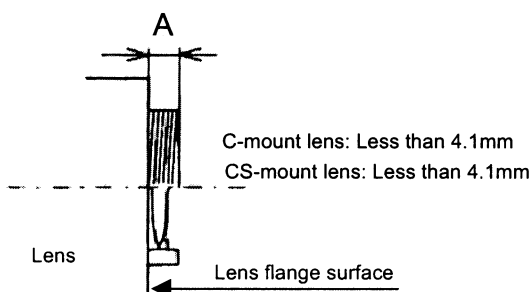

## Lens selector switch

Set the switch according to the type of auto-iris lens.  
The factory setting is DC.



DC : Set to DC when using a lens having a DC Control voltage input.

VIDEO : Set to VIDEO when using a lens having a Video signal input.

### Notes:

1. To the extent possible, set the lens response to Average. Hunting can occur toward the Peak setting.
2. When adjusting the level, choose a location with adequate brightness (more than 300 lux) where the AGC and Sens Up functions are not needed.

## Lens connector

When using an auto iris lens, install the lens plug on the lens Cable as indicated in the figures. Refer to the lens instructions Regarding the signals and wire colors.

### DC type lens

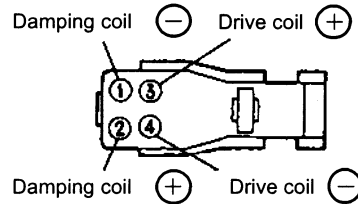

### Video type lens

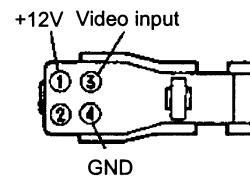

After installing the plug on the cable, connect it to the lens connector on the rear of the camera.

9

## Flangeback adjustment

Flangeback adjustment is needed in cases where focus cannot be obtained by normal lens focus operation or focus is lost at the maximum telephoto and wide angle settings of a zoom lens.

In such cases, open the lens iris and adjust as follows.

### Fixed focus lens

- 1) Set the lens focus ring to infinity.
- 2) Aim toward an object at least 20 meters distant.
- 3) Loosen the (2) lens mount screws and turn the lens mount ring to adjust the focus. Use care not to disturb the lens focus ring.
- 4) Tighten the lens mount screws.

### Note:

If using an auto iris lens and the adjustment object distance is less than several meters, due to lens depth of focus relationship, slight blurring can occur at certain iris positions. In this event, darken the scene so as to open the iris and adjust the focus or flangeback to prevent the blurring.

## Zoom lens

- 1) Set the lens to telephoto and aim toward an object at least 20 meters distant.
- 2) Turn the lens focus ring to adjust the focus.
- 3) Set the lens to wide angle. Loosen the (2) lens mount screws and turn the lens mount ring to adjust the focus. Use care not to disturb the lens focus ring.
- 4) Again set to telephoto but adjust the focus by turning the lens mount.
- 5) Repeat these steps and carefully adjust for best focus.
- 6) Finally, tighten the lens mount screws.

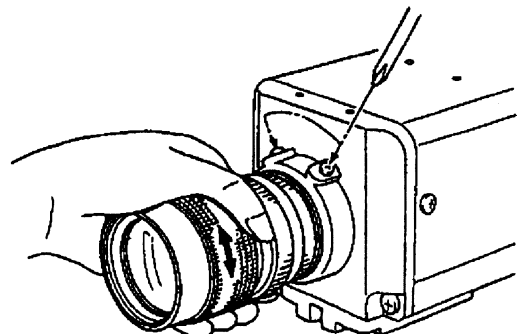

# Camera mounting

If the camera is to be suspended from the ceiling, change the position of the tripod adaptor from the bottom to the top of the camera, as indicated in the figure.

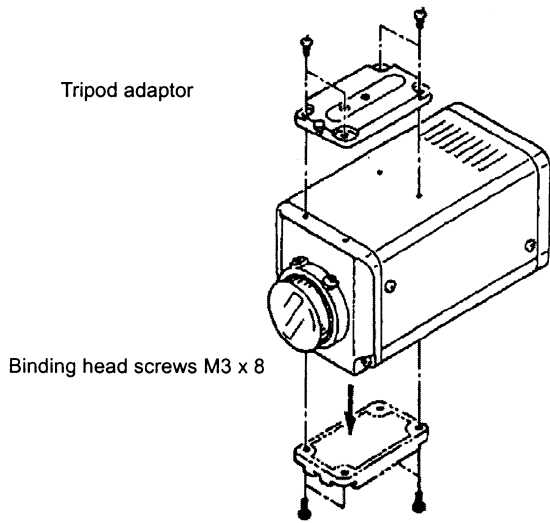

### Caution:

Use the following type of camera mounting screw.

Type :U 1/4-20  
Length:L=7mm

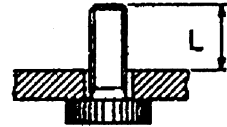

If longer than 7 mm, there is risk of internal damage to the camera. Conversely, if too short, the camera will not be firmly secured and there is risk of dropping.

# Setting menu description

The camera setting and adjustments can be changed to conform to conditions of use. Use the setting menu indicated on the monitor screen to check and change the settings and adjustments. The setting menu is comprised as follows.

## Setting menu composition

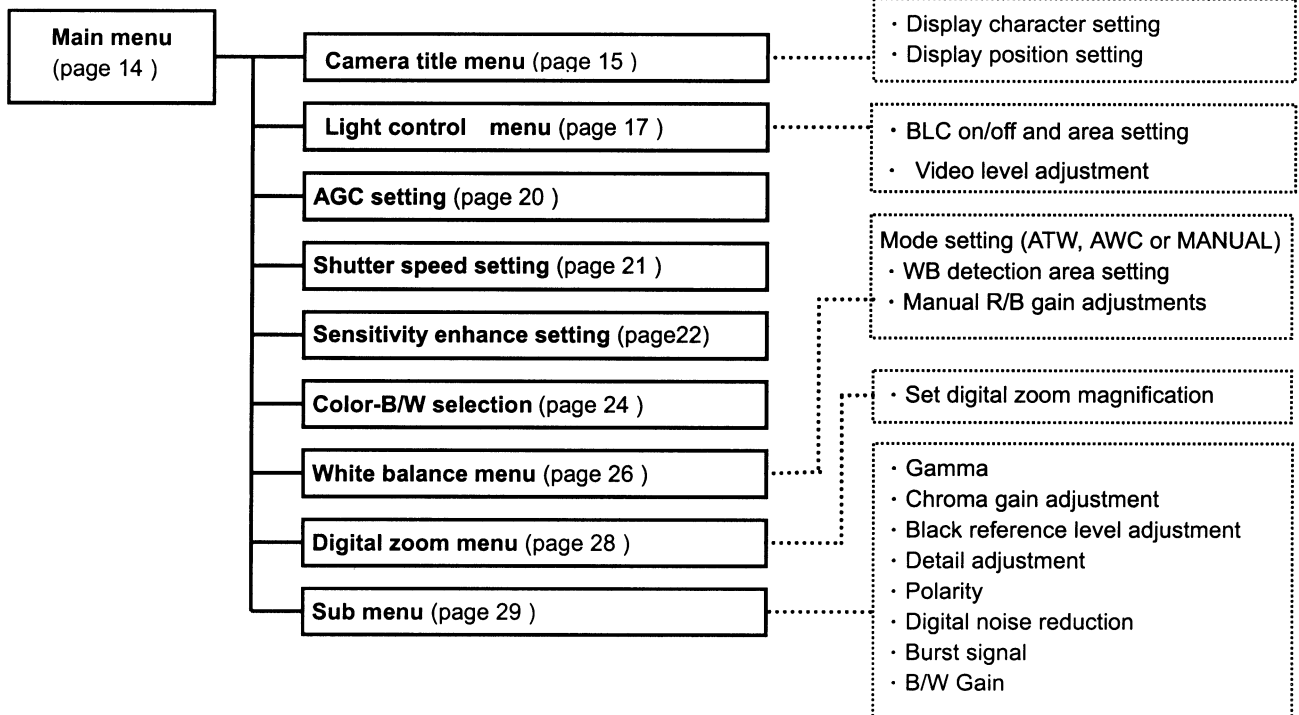

## Menu operations

Three rear panel setup buttons are used to shift the cursor and select items from the menus.

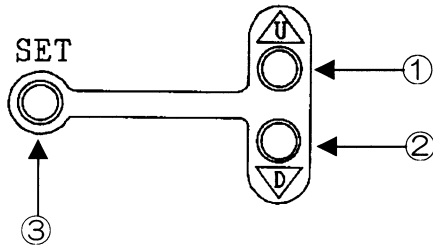

### ① Up button:

Shift the cursor in the upward direction or increase an adjustment value.

### ② Down button:

Shift the cursor in the downward direction or increase an adjustment value.

### ③ Set button:

Press to display the main menu or to change a setting.

13

## Main menu

1) Press the Set button for at least 2 seconds to display the main menu on the monitor screen.

<<< MAIN MENU >>>	
>TITLE : OFF ↵	.....Title menu
LIGHT CONTROL : OFF ↵	.....Light control menu
AGC : ON (31dB)	.....AGC setting
SHUTTER SPEED : OFF	.....Shutter speed setting
SENS UP : OFF	.....Sensitivity enhance Setting
B/W MODE : AUTO (MID)	.....B/W mode setting
WHITE BALANCE : ATW ↵	.....White balance menu
DIGITAL ZOOM : OFF ↵	.....Digital zoom
SUB MENU ↵	.....Sub menu
END	.....End

Main menu

- 2) Check the present settings at the main menu.
- 3) Shift the cursor vertically by pressing the Up and Down buttons, then press the Set button to enable changing the setting of the selected item.
- 4) If changes are unnecessary, shift the cursor to End and press the Set button to return to the normal screen.
- 5) Changed settings are stored in the camera memory (EEPROM) and returned the next time the camera power is switched on.

When an item indicated by a ↵ mark is selected, pressing the Set button shifts to the next menu.

### Note:

If no button is pressed, the menu display extinguishes automatically after about 5 minutes.

## Title menu

One line of up to 24 alphanumeric characters can be displayed on the screen. The display on/off and position are selected at the Title menu.

- 1) Press the Set button for longer than 2 seconds to display the Main menu.
- 2) Use the Up and Down buttons to shift the cursor to Title, then press the Set button to display the Title menu.

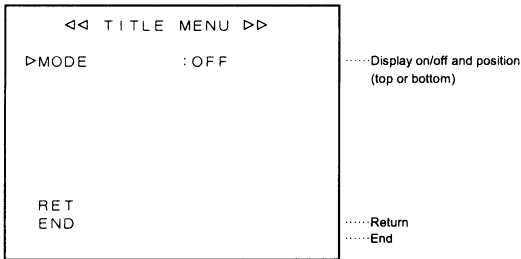

Title menu (off mode selected)

- 3) While the cursor is at Mode, press the Set button to shift the mode in the sequence Off, Top, Bottom.

### OFF

Characters not displayed.

### TOP

Characters displayed at top of screen.

### BOTTOM

Characters displayed at bottom of screen.

### Display character input

- 1) When the mode is Top or Bottom, the characters indicated in the figure can be used.
- 2) Press the Down button, then use the Up and Down buttons to shift the flashing cursor sequentially among the usable characters. Shifting is speeded when the button is held depressed.

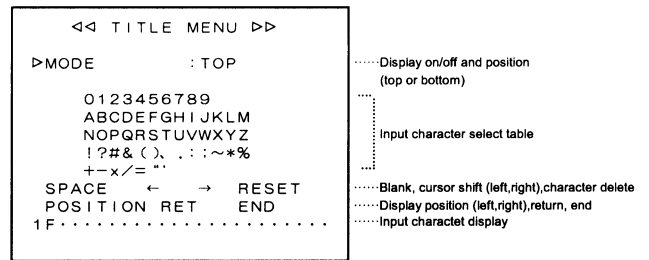

Title menu

- 3) When the Set button is pressed, the selected character is entered in sequence beginning with the left-most of 24 dots shown at the bottom of the screen. Afterwards, each newly selected character is entered sequentially toward the right.

### Note:

At the end of character setting, remaining rightward dots are not shown on the monitor screen.

Additional commands of the title input menu are as follows.

### SPACE

To add a blank space, shift the flashing cursor to Space, then press the Set button.

← · →

The input characters can be edited by using the arrow symbols.

- 1) Set the flashing cursor to either of the arrow symbols and press Set. The flashing cursor shifts in the arrow direction. Press the Set button repeatedly to where the flashing cursor overlaps the character to be changed.
- 2) Select the character to be inserted with the Up and Down buttons, then press Set to change the character.

### RESET

To delete all characters from the display, shift the flashing cursor to Reset, then press Set. After deleting, the flashing cursor returns to the start of the input character select table.

### RET

Position the flashing cursor to RET and press Set to exit the title menu and return to the main menu.

### END

Shift the cursor to End and press the Set button to close the menu and return to the normal screen.

### Title positioning setting

#### POSITION

Use when the display position on the screen has been determined.

- 1) Shift the flashing cursor to Position and press Set to open the title position screen indicated in the figure. Screen top and bottom positions are determined respectively by Mode settings Top and Bottom.
- 2) Press the Up and Down buttons to shift the characters horizontally. Afterwards, press Set to confirm the display position and return to the main menu.

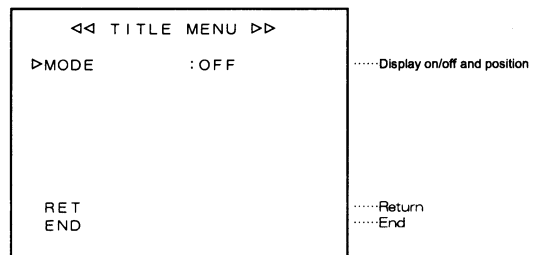

Title menu



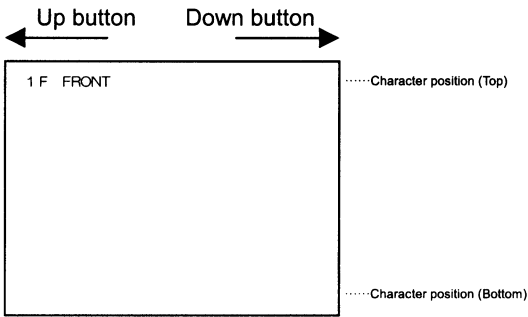

**Title positioning screen (Top)**

**Light control menu**

**Detection area setting**

- 1) Press the Set button for longer than 2 seconds to display the Main menu.
- 2) Use the Up and Down buttons to shift the cursor to Light control; OFF/ON flashes. At ON, the presently set light detect area numbers are displayed. Press the Set button to then open the Light control menu.

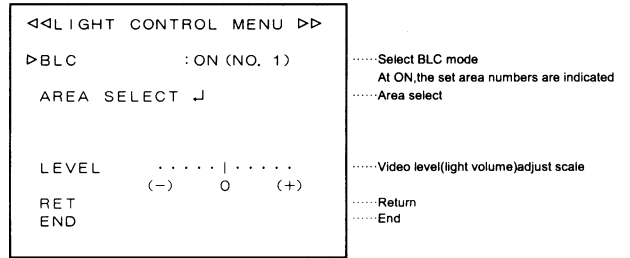

**Light control menu**



- 3) Shift the cursor to BLC and press the Set button to toggle between ON and OFF. When ON, Area Select is displayed.
- 4) Shift the cursor to Area Select and press the Set button to display the detection area select menu.

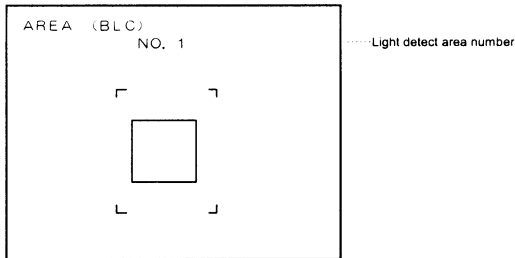

**Detect area indication (no.1)**

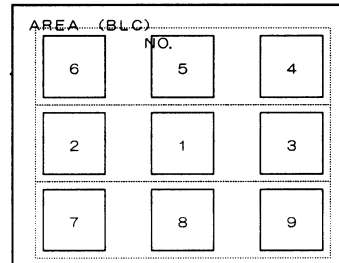

**Detect area positions**

When using a DC control voltage type lens, the detection area can be selected from 9 locations shown in the figure. If using a video signal type lens, three horizontally adjacent locations (indicated by dotted lines in the figure) can be selected (any number in a horizontal group can be chosen).

- 5) There are 9 light detect areas selected by the Up and Down buttons. Select the areas from nos. 1 to 9 that include the subject of main interest.

Up button : 1→2→3→4→5→6→7→8→9  
(ascending order)

Down button: 9→8→7→6→5→4→3→2→1  
(descending order)

6)After deciding the detection areas, press the Set button to return to the light control menu.

### Back light compensation

The lens iris closes in response to strong light (such as from a spotlight or window) entering the scene background to darken the subject of interest. when using a DC type lens, set BLC to ON to open the lens iris and avoid blacking out the subject of interest (set the detect areas to match the subject). The factory setting is OFF.

**Note:**

when using a video signal type lens, the back light compensation is fixed, regardless of the setting.

### Video level adjustment

The optimum video level is set at the factory. If necessary, the level can be changed as follows.

- 1) Use the Up and Down buttons to shift the cursor to Level, then press the Set button. The adjustment scale at the right of Level flashes.
- 2) Change the video level by pressing the Up and Down buttons. Holding a button depressed speeds the cursor shift.
- 3) Press the Set button to confirm the setting.
- 4) Return the initial (central) setting by simultaneously pressing the Up and Down buttons for two seconds.

when using a video signal type lens, setting the lens switch to Video extinguishes the scale and fixes the level to the factory setting. To adjust the video level, refer to the lens instructions and adjust the lens sensitivity.

### Agc setting

- 1) Press the Set button for longer than 2 seconds to display the Main menu.
- 2) Use the Up and Down buttons to shift the cursor to AGC; the AGC setting flashes. Then press Set to change the maximum gain.  
OFF→ON(6 dB)→ON(12 dB)→ON(21 dB)  
→ON(31 dB)→ON(MAX)

Numerals indicate the maximum gain.

At MAX, the maximum gain corresponds to about 37 dB. The factory setting is ON (31 dB). When AGC is ON and the scene darkens to where the iris of an auto iris lens is fully open, the circuit gain is automatically increased within the maximum range to obtain a suitable video level.

**Note:**

At AGC off, the B/W mode setting defaults to off. To use the B/W mode, first set the AGC to on, then again set the B/W mode to on.

At AGC on, dark scene components are more easily seen, but noise becomes more apparent.

The DNR (digital noise reduction) function of the sub menu can be used if noise is objectionable at AGC on (31 dB) or MAX settings. See description on Page 30 .

```
<<< MAIN MENU >>>
TITLE          :OFF  J
LIGHT CONTROL :OFF  J
▷AGC           :ON (31dB)
SHUTTER SPEED :OFF
SENS UP       :OFF
B/W MODE      :AUTO(MID)
WHITE BALANCE :ATW  J
DIGITAL ZOOM  :OFF  J
SUB MENU     J
END
```

Main menu

## Shutter speed setting

- 1) Press the Set button for longer than 2 seconds to display the Main menu.
- 2) Use the Up and Down buttons to shift the cursor to Shutter speed; the shutter speed setting flashes.
- 3) Press the Set button to select the speed sequentially in the following order.  
OFF(1/60)→1/100→1/250→1/500→1/1000→1/2000→1/4000→1/10000→1/20000→1/30000→AES  
The factory setting is OFF (1/60 second).

```
<<< MAIN MENU >>>
TITLE          : OFF  ↓
LIGHT CONTROL  : OFF  ↓
AGC            : ON (31dB)
▷SHUTTER SPEED: OFF
B/W MODE       : AUTO(MID)
SENS UP        : OFF
WHITE BALANCE  : ATW  ↓
DIGITAL ZOOM   : OFF  ↓
SUB MENU      :      ↓
END
```

Main menu

## Auto electronic shutter (AES)

This function adjusts the light amount using only the CCD shutter. Use this function with a fixed iris lens.  
If using a DC type lens, fix the iris at fully open.  
The AES function cannot be set with a video signal type lens.

### Note:

In the following types of cases, use a different shutter speed.  
Strong light enters the scene, such as from a spotlight or window.

- Strong smear or blooming occurs in the scene.
- Screen flicker or coloration occurs.

21

## Sensitivity enhance setting

The present camera includes a sensitivity enhancement function that increases the CCD exposure time and interpolates the image with an image stored in memory to effectively boost the sensitivity.

- 1) Press the Set button for longer than 2 seconds to display the Main menu.
- 2) Use the Up and Down buttons to shift the cursor to SENS UP; the setting flashes.
- 3) Press the Set button to select the setting sequentially in the following order.

OFF→AUTOX2→AUTOX4→AUTOX6→AUTOX8→  
AUTOX10→AUTOX12→AUTOX16→AUTOX32→  
AUTOX64→OFF→  
MANUALX2→MANUALX4→MANUALX6→  
MANUALX8→MANUALX10→MANUALX12→  
MANUALX16→MANUALX32→MANUALX64→

## OFF

Sensitivity enhance function not used; factory setting.

## AUTO

As the scene darkens, the sensitivity is automatically enhanced by the selected multiple. Best mode for day/night continuous surveillance.

## MANUAL

Mode for fixed sensitivity boost. When AGC is ON, fixed at maximum gain.

```
<<< MAIN MENU >>>
TITLE          : OFF  ↓
LIGHT CONTROL  : OFF  ↓
AGC            : ON (31dB)
SHUTTER SPEED  : OFF
▷SENS UP       : OFF
B/W MODE       : AUTO(MID)
WHITE BALANCE  : ATW  ↓
DIGITAL ZOOM   : OFF  ↓
SUB MENU      :      ↓
END
```

..... Set to OFF by holding the Set button depressed for 2 seconds.

Main menu

### Note:

At AGC off, the B/W mode setting defaults to off. To use the B/W mode, first set the AGC to on, then again set the B/W mode to on.

**Notes:**

- Enhanced sensitivity can cause blurring of moving images. In the following types of cases, reduce the sensitivity multiple.
- When operating via the Remote connector, the Remote commands have priority.
  - Noise increases at high sensitivity and further increases at high frequency.
  - The Shutter speed cannot be changed during Auto and Manual SENS UP settings. Temporarily set SENS UP to OFF when changing the Shutter speed.
  - If noise is objectionable at high sensitivity, set DNR of the Sub menu to ON. Conversely, if image lag of moving images is objectionable, set DNR to OFF.
  - White flaws may become apparent at high sensitivity, but these are not due to malfunction.

When SENS UP setting is Manual, the shutter speed setting is ineffective (off).

At SENS UP Auto, the shutter speed setting is as follows.

- 1) Shutter speed is 1/100 or effective during AES.
- 2) Shutter speed is 1/100 and ineffective (off) in modes other AES.

**The setting state of shutter speed**

		SENS UP Setting		
		OFF	MANUAL	AUTO
<b>SHUTTER SPEED Setting</b>	<b>OFF</b>	<b>OFF</b>	<b>OFF</b>	<b>OFF</b>
	<b>1/100</b>	<b>1/100</b>	<b>→OFF</b>	<b>1/100</b>
	<b>1/250</b>	<b>1/250</b>	<b>→OFF</b>	<b>→OFF</b>
	<b>1/30000</b>	<b>1/30000</b>		
	<b>AES</b>	<b>AES</b>	<b>AES</b>	<b>AES</b>

**Raising sensitivity by color-B/W selection**

- 1) Press the Set button for more than 2 seconds to show the main menu.
- 2) Press the up and down buttons to position the cursor to B/W mode (flashes). Press the Set button to select the mode in the sequence of OFF→ON→AUTO(HI)→AUTO(MID)→AUTO(LOW).  
The factory setting is AUTO(MID).

OFF : Color always mode

ON : B/W always mode

AUTO: Mode selected in response to brightness.

Can be set for high, medium or low.

Brightness auto selection time differs with the scene, but may take as long as a minute in some cases.

**Color-B/W selection**

The camera CCD responds to infrared light that is invisible to the human eye. The normal color mode uses an IR cut filter to remove the infrared component.

Sensitivity is usually more important in the B/W mode.

Therefore, the IR cut filter is removed to take advantage of sensitivity in the infrared region. The B/W gain can be adjusted at the sub menu. See Page 30.

```

<<< MAIN MENU >>>
TITLE           :OFF  J
LIGHT CONTROL  :OFF  J
AGC            :ON (31dB)
SHUTTER SPEED :OFF
SENS UP       :OFF
▷B/W MODE     :AUTO(MID) .....Infrared cut filter off
WHITE BALANCE :ATW  J
DIGITAL ZOOM  :OFF  J
SUB MENU     J
END
    
```

**Main menu**



The B/W mode defaults to off at settings indicated by × below.

- 1) AGC off: First set AGC to on to use the B/W mode.
- 2) Sens Up: Manual To use the B/W mode, first set Sens Up to manual or auto.

		AGC : ON			AGC : OFF		
		SENS UP			SENS UP		
		OFF	AUTO	MANUAL	OFF	AUTO	MANUAL
B/W MODE	OFF	OFF	OFF	OFF	OFF	OFF	OFF
	ON	ON	ON	(OFF) →×	(OFF) →×	(OFF) →×	(OFF) →×
	AUTO	AUTO	AUTO	(OFF) →×	(OFF) →×	(OFF) →×	(OFF) →×

When the B/W mode is on or auto, the sub menu gain is fixed at -128 and cannot be adjusted.



### White balance menu

Three methods of white balance control are provided. The appropriate method can be selected according to Conditions of use.

- 1) Press the Set button for longer than 2 seconds to display the Main menu.
- 2) Shift the cursor to White Balance and press Set to open the white balance menu.
- 3) Press Set to select the mode in the sequence ATW - AWC - MANUAL.

**Note:**  
 ATW does not function properly in the following types of situations. In such cases, use Manual adjustment. Most of the scene is one color, with very little white. Under sodium or other special types of lighting. Background is red or blue.

#### ATW (auto tracking white balance)

Factory setting, suitable for automatically tracking the color temperature in the range of 2500 to 8000 K.

#### AWC (preset white balance)

- 1) When AWC is selected, SET AWC flashes.

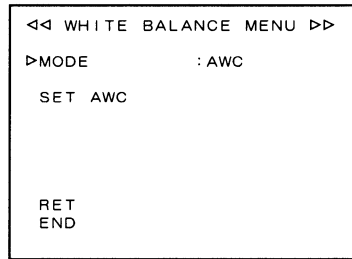
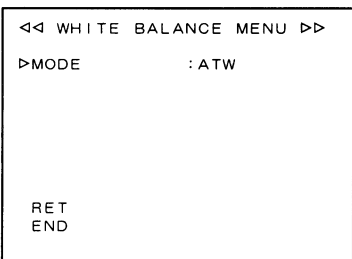

White balance menu (ATW)

White balance menu (AWC)

2) Under the illumination used at the installation site, pickup the color white. Press the Down button to begin automatic white balance adjustment. When completed, SET AWC extinguishes. The automatic process takes several seconds, but if more than 10 seconds elapse, rearrange the scene so that white occupies more of the screen area and repeat the adjustment.

### Manual

- 1) Select the Manual mode to display the red and blue gain adjust scales.
- 2) Shift the cursor to the scale of the color to be adjusted with the Up and Down buttons.
- 3) Press the Set button; the scale cursor flashes.
- 4) Press the Up and Down buttons to adjust blue gain, then press Set to confirm the gain. Simultaneously press the Up and Down buttons for 2 seconds to return the initial (center) setting.
- 5) After adjusting, press the Set button; RET flashes. Again press the Set button to return to the main menu.

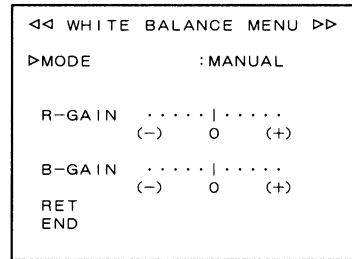

.....Select white balance mode for ATW,AWCor Manual  
 .....R gain adjust scale  
 .....B gain adjust scale  
 .....Return  
 .....End

**White balance menu (Manual)**

**Notes:**  
 White balance cannot be fully adjusted in the following situations.

- Most of the scene is a single color or there is very little white component.
- Special lighting such as mercury or sodium vapor.
- Background is red or blue.

White balance cannot be adjusted when the B/W mode is on.

### Digital zoom

- 1) Press the Set button for longer than 2 seconds to display the Main menu.
- 2) Shift the cursor to Digital Zoom and press the Set button to open the digital zoom menu.

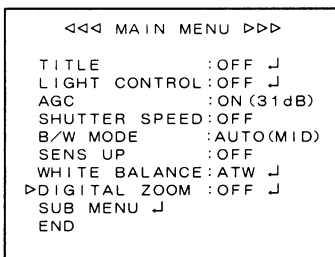

**Main menu**

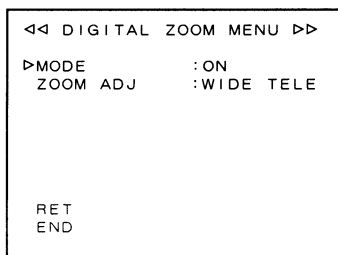

**Digital zoom menu**

.....Digital zoom mode on/off  
 .....Zoom magnification  
 .....Return  
 .....End

- 3) Shift the cursor to Mode and press the Set button to toggle between on and off. At OFF (factory setting), the zoom magnification is fixed at 1. In the ON mode, Zoom Adj is displayed and indicates the previously set zoom magnification.
- 4) To change the zoom magnification, set the mode to ON. Shift the cursor with the Up and Down buttons to Zoom Adj and press the Set button.
- 5) Wide and Tele flash. Change the zoom magnification with the Up and Down buttons. Maximum setting is 4X.
- 6) Press the Set button to confirm the setting and stop the flashing.

**Note:**  
 The digital zoom function uses the internal memory to enlarge the image without utilizing a zoom lens. The picture quality deteriorates as the magnification increases. There may also be a change in video level. The function is not suitable for a video signal type auto iris lens. Use the digital zoom with a fixed or DC voltage type lens. When using the digital zoom, the sub menu B/W gain defaults to off. The DNR function defaults to off when the digital zoom magnification is varied. Although noise increases, this is normal.

## Sub menu

The sub menu is used for changing the picture quality (video response) of the camera output image.

- 1) Press the Set button for longer than 2 seconds to display the Main menu.
- 2) Shift the cursor to Sub Menu and press the Set button to open the sub menu.

<< SUB MENU >>		
>GAMMA	: ON	.....Gamma on/off
CHROMA GAIN	: 000	.....Color level setting
REDESTAL	: 000	.....Pedestal level setting
DETAIL	: 000	.....Detail level setting
POLARITY	: POSITIVE	.....Negative/positive
DNR	: ON	.....Noise reduction on/off
BURST	: ON	.....Burst signal on/off
B/W GAIN	: OFF	.....B/W gain on/off
RET		.....Return
END		.....End

Sub menu

## Gamma

Shift the cursor with the Up and Down buttons to Gamma, then press the Set button to toggle on/off.

## Chroma gain

The optimum color level has been set at the factory.

If necessary, this can be changed as follows.

- 1) Shift the cursor to Chroma Gain with the Up and Down buttons and press the Set button; the numerals flash.
- 2) Press the Up and Down buttons to change the level (-128 to 000 to +127). Press continuously to speed change. Press the Up and Down buttons simultaneously for 2 seconds to return the initial (000) setting.
- 3) Press the Set button to confirm the setting and stop the flashing.

## Pedestal (black reference level) setting

The optimum black reference level has been set at the factory. If necessary, this can be changed as follows.

- 1) Shift the cursor to Pedestal with the Up and Down buttons and press the Set button; the numerals flash.
- 2) Press the Up and Down buttons to change the level (-128 to 000 to +127). Press continuously to speed change. Press the Up and Down buttons simultaneously for 2 seconds to return the initial (000) setting.
- 3) Press the Set button to confirm the setting and stop the flashing.

29

## Detail level

The optimum detail level has been set at the factory.

If necessary, this can be changed as follows.

- 1) Shift the cursor to Detail with the Up and Down buttons and press the Set button; the numerals flash.
- 2) Press the Up and Down buttons to change the level (-128 to 000 to +127). Press continuously to speed change. Press the Up and Down buttons simultaneously for 2 seconds to return the initial (000) setting.
- 3) Press the Set button to confirm the setting and stop the flashing.

## Polarity

The factory setting is positive. Shift the cursor to Polarity and press the Set button to toggle between positive and negative.

The negative polarity is convenient when using negative material, such as negative film.

## Digital noise reduction (DNR)

At low illumination (below 2 lux), DNR reduces noise at AGC gain up setting. The DNR function operates below about 2 lux at AGC on 31 dB or Max settings. Position the cursor at DNR and press the Set button to toggle on/off.

When motion in the scene is small, the on setting can reduce AGC noise. Set to off if lag is intrusive with a moving image.

Factory setting is on.

## Note:

The AGC must be set to on 31 dB or Max for DNR to function. Otherwise DNR does not operate even if set to on. The function also does not operate unless scene light is below about 2 lux. At DNR on, image lag may become apparent in moving images.

## Burst signal setting

The burst signal is set when the B/W mode is on or a B/W image operates during Auto.

When on, the burst signal output is produced even with a B/W image. When off, the burst signal output is not produced. Factory setting is on.

## B/W gain setting

Gain is increased about 6 dB during B/W operation.

Even if dark, change the setting when on.

Factory setting is off.

When the B/W gain is on, the digital zoom defaults to off.

## Color Temperature and white balance adjustment

Color temperature is one of the properties of light. The unit is Kelvin (K), with 0 K equivalent to -273°C.

The color temperature of a light source is related to the type of illumination and sky conditions. It is not directly related to brightness. A high color temperature is bluish, while a low color temperature is reddish.

Since the response of the human eye is adaptive, changes in color are not sensed even with changes in ambient illumination. However, a camera reproduces color temperature differences to result in different color appearance compared to direct viewing by eye. White balance adjustment serves to compensate for these differences in color temperature.

This camera is provided with automatic tracking white balance (ATW ON) mode. The factory setting is ATW ON.

### Color temperature, illumination and sky conditions

Color temperature (K)	sky conditions	illumination
10,000	clear blue sky	
8,000	Twilight	
7,000	Cloudy sky	Xenon arc
	Bright rain	
	Daylight	
5,000	Midday sunlight	
	2 hours after sunlight	Fluorescent lamp
4,000		
3,500	1 hours after sunlight	
3,000		Halogen lamp, Iodine lamp
		100W to 500W gas filled bulb
		100W tungsten lamp
2,500		60W tungsten lamp
	Around sunrise	Candle

31

## Remote menu operation

An optional remote plug is available to enable operating the camera direction and set buttons by remote control. Confirm the plug is properly wired as indicated in the figure and connect it to the rear panel Remote connector. Do not connect anything to the unused Pins.

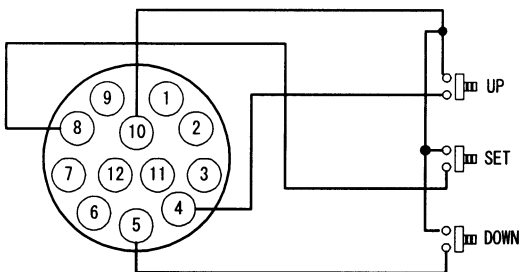

Remote plug(option)

### External key switch connections for remote operation

Keep the distance between the remote plug and external key switches to less than about 2 meters. Disconnect the remote plug from the camera Remote connector when not using the key switches.

#### Note:

Be sure to switch off the camera power before connecting or disconnecting the remote plug.

Pin	Signal	Abbrev.	Remarks
1	Not connected	N.C.	Do not connect
2	Serial data input	Tx	Connect to RS-232C data terminal
3	Serial data output	Rx	Connect to RS-232C data terminal
4	Up key	UP	Key switch connection
5	Down key	DOWN	Key switch connection
6	Not connected	N.C.	Do not connect
7	Not connected	N.C.	Do not connect
8	Set key	SET	Key switch connection
9	Not connected	N.C.	Do not connect
10	GND	GND	Connect to RS-232C ground
11	Not connected	N.C.	Do not connect
12	Not connected	N.C.	Do not connect

### Remote operation with RS-232C

Signals 2, 3 and 10 can be used for control by personal computer. Consult dealer for detailed information.



# Remote sensitivity operation

An optional remote plug is available to enable remotely controlling the sensitivity setting, sensitivity mode (auto/manual), AGC and DNR functions. The plug is wired as shown in the figure and connected to the camera rear panel Remote connector. See page\*\*.

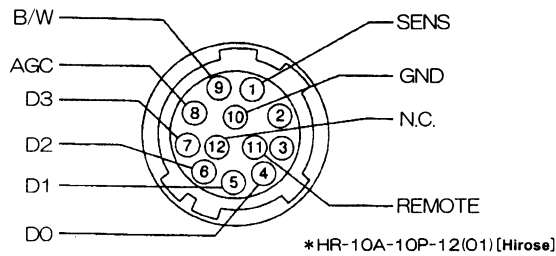

(Viewed from engagement side)

**Notes:**

- When the plug is connected, remote operation has priority.
- White specks can appear in the image at high sensitivity. This is not due to malfunction.
- The CCD integration time increases at high sensitivity and blurring can occur with moving objects.

**Remote sensitivity switch connections**

Confirm the switches are wired as indicated in the figure.

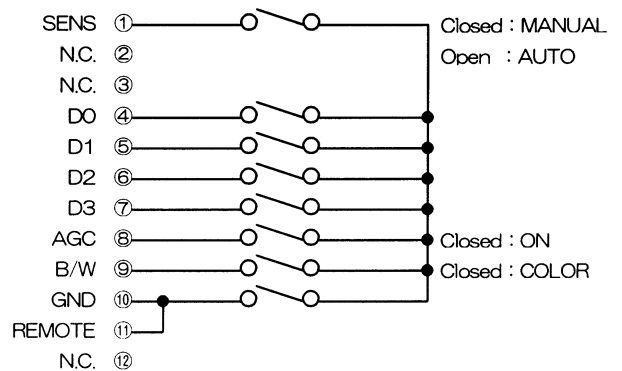

At manual sensitivity settings, refer to the table for maximum settings. Sensitivity is selected automatically between standard and maximum.

See Page 25 for settings with B/W mode on. Set AGC and Sens Up to where the B/W mode is not switched off.

Sens Up is off when D0 - D3 are all open.

The menu is not produced when the plug is connected.

Switch off power when connecting the plug.

However, even if multiples 128 to 510 are set in AUTO, the sensitivity is fixed.

**Sensitivity setting**

D3	D2	D1	D0	Multiple
0	0	0	0	1 (OFF)
0	0	0	1	2
0	0	1	0	4
0	0	1	1	6
0	1	0	0	8
0	1	0	1	10
0	1	1	0	12
0	1	1	1	16
1	0	0	0	32
1	0	0	1	64
1	0	1	0	*128
1	0	1	1	*164
1	1	0	0	*256
1	1	0	1	*320
1	1	1	0	*420
1	1	1	1	*510

1 : SW ON (closed)      0 : SW OFF (open)

Pin	Signal	Abbrev.	Remarks
1	SENS AUTO/MANU	SENS	Sensitivity boost mode select
2	N.C.	N.C.	Do not connect
3	N.C.	N.C.	Do not connect
4	D0	D0	Sensitivity setting
5	D1	D1	Sensitivity setting
6	D2	D2	Sensitivity setting
7	D3	D3	Sensitivity setting
8	AGC ON/OFF	AGC	AGC ON/OFF select
9	B/W MODE	B/W	Color-B/W select
10	GND	GND	GND
11	REMOTE	REMOTE	Connect to pin 10 (GND) to control
12	N.C.	N.C.	Do not connect

**Note:**

Error can occur if the camera set buttons are operated while the remote plug connected.

# Specifications

- 1.Color system** NTSC  
**2.Pickup element** Interline transfer type CCD  
 Total pixels 811(H)× 508(V)  
 Effective pixels 768(H)× 494(V)  
 Scanning area 6.45(H)× 4.84(V)mm  
 Sell size 8.4(H)× 9.8(V)μm  
**3.Scanning system** 2:1 interlace  
**4.Scanning frequency** Hor. 15.734kHz  
 Ver. 59.94Hz  
**5.Sync system** internal  
**6.Signal processing** Internal digital processing  
 (input:12 bits,output:8 bits)  
**7.Video signal output** VBS1.0Vp-p/75Ω  
**8.Resolution**

	Standard sensitivity	Sensitivity boost
Hor.	480 lines	440 lines
Ver.	350 lines	260 lines

- 9.S/N(luminance signal)** More than 50dB  
 (AGC,enhancer and gamma OFF)  
**10.Minimum illumination**  
 Standard sensitivity Color :0.2lx  
 Black&White:0.02lx  
 (F1.4, 3200K, AGC:MAX, Tungsten lamp)

\* If even greater sensitivity is required, electronic sensitive can be increased up to 32 times.

- 11.Scene illumination range** 0.02~100,000 lx  
 (when using auto-iris lens)  
**12.Color-Black&White select**  
 OFF (Color always mode)  
 ON (B/W always mode)  
 AUTO(Mode selected in response to brightness)  
 Can be set for high, medium or low  
**13.Sensitivity setting** AGC ON/OFF selectable  
 Max.gain AGC ON settable  
 Sensitivity settable up to 32 X  
 SENS UP:AUTO Sensitivity settable up to 64 X  
 SENS UP:MANUAL  
**14.White balance** Selectable auto-tracking(ATW),  
 preset(AWC),Manual  
**15.Auto-iris lens outputs**

Video signal Input type lens	Luminance signal 1.0Vp-p/high impedance Power supply 12V DC 60mA
Iris control voltage input (galvanometer)	Coupling coil impedance Damper:1150Ω±10% Drive:190Ω±10%

- 16.Backlight compensation** ON/OFFswitchable  
 Sensing area:selectable from 9 areas  
**17.Electronic shutter speeds** OFF(1/60),1/100,1/250,1/500  
 1/1000,1/2000,1/4000,1/10000  
 1/20000,1/30000,AES

35

- 18.Text display** 24 characters at top or bottom in one line  
**19.Noise reduction** ON/OFF settable  
**20.Digital zoom** ON/OFF (Up to X4)  
**21.Lens mount** C/CS mount  
**22.Ambient temperature**  
 -10~+50°C、30~80%RH  
**23.Storage ambient** -20~+60°C、20~90%RH  
**24.Power supply** AC100V±10%、50/60Hz  
**25.Power consumption** 6.7W  
**26.External dimensions** 64 (W) × 63 (H) × 123 (D) mm  
**27.Mass** Approx. 600g

## Note:

If used continuously, be sure to operate at less than 40°C for long term stable performance.

## Accessories

### Supplied accessories

Operation manual	1
Lens plug (E4-191 -100)	1 (JPE0001)
Fuse (125V 0.63A)	1 (EFG0655)

### Warning:

The fuse must be replaced only by a qualified service technician.

### Optional accessories

Lenses (see Page 7 )	
Remote plug	HR-10A-10P-12P(01) (JMH0093)

## Operating considerations

### Power supply

Be sure to use the power source specified in the Major Specifications.

- Before plugging or unplugging a connector, be sure to turn off power.

To plug or unplug a connector, be sure to hold the connector section.

- Note that it will take several seconds until a picture is displayed on the monitor after power on.

### Handling

- Do not attempt to remove cover.
- When installing or removing a lens, be sure to use care that water or dust does not enter the inside of the camera.

### Installing and storage

Avoid installing or storing the camera in the following environments.

- Environments exposed to direct sunlight, rain or snow
- Environments where combustible or corrosive gas exists
- Excessively warm or cold environment (Operating ambient temperature: -10 to 50°C)
- Humid or dusty environment
- Place subjected to excessive vibration or shock
- Environment exposed to strong electric or magnetic field

- Do not aim the camera lens at the sun.
- Do not shoot strong light or a scene including strong light. When such a scene is shot, vertical trailings will appear. However, this is not due to failure. In case strong light enters the camera through the lens, partial deterioration in picture quality will result.

### To obtain stable performance for long time

When the camera is used continuously for long time under high ambient temperature, the inside electrical parts become deteriorated, resulting in shortening its life. To use the camera continuously for long time, the highest temperature must be below 40°C.

### Cleaning

- Use a blower or a lens brush to remove dusts on the lens or the optical filter.
- Wipe dirt on the case off with dry soft cloth. If dirt is hardened, wipe them off with cloth moistened with neutral detergent liquid; wipe the cover with dry cloth.
- Do not use benzine, thinner, alcohol, liquid cleaner or spray-type cleaner.
- In event dust or other debris is lodged between the CCD and optical filter, consult dealer for cleaning by an optical technician.

2

## Phenomena inherent to CCD imaging device

Following are the phenomena inherent to a CCD imaging device, and not defects

### 1) Smear and blooming

When strong light (lamp, fluorescent lamp, reflected light, etc.) is shot, pale bands are displayed vertically above and below the light.

In this case, change the angle of the camera so that such strong light does not enter the camera through the lens.

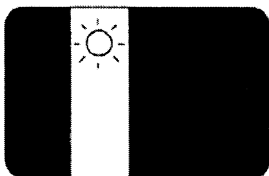

### 2) Fixed pattern noise

When the camera is operated in a high temperature, fixed pattern noise may appear on the entire screen.

### 3) Moire

When fine patterns are shot, moire may be displayed.

### 4) Burning

When excessively intense light comes to the CCD for a long time, the spectral filter in the CCD pixel may be deteriorated, and the color of the corresponding portion may change.

Avoid using the camera under such condition.